

Installation Manual for A2FFF Cable Gland

A2FFF Series of Flameproof and Increased Safety Cable Glands for Flat Form Cables

Please read all instructions carefully before beginning the installation
CABTEK A2FFF type Cable Glands are for Indoor and Outdoor use in the appropriate Hazardous areas with unarmored cable. The seal on the outer jacket and give environmental protection to IP66/67. They are suitable for normal industrial environmental of temperature, humidity and vibration.

Cable Glands are made of Brass CW614N/SS 316L assembled with VMQ Silicone Rubber and Nylon Substrate.

Material Compatibility under chemical corrosion or attack by aggressive substance must be considered before installation.

Cable Gland confirm to following Standards for Group II, Category-2 for Zone 1, 2, 21 & 22 for ambient temperature range -60°C to +135°C.

Standards Applied: EN IEC 60079-0:2018

EN/IEC 60079-1:2014

EN/IEC 60079-31:2014/2013

Ex marking on A2FFF type Cable Glands:

20sA2FFF M20 II 2 GD CE 2903

Ex db IIC Gb, Ex eb IIC Gb.....
 Ex tb IIIC Db IP66/67
 -60°C to +135°C, ETL22ATEX0109X, IECEx ITS 16.0041X
 RU C-IN.X58.B.03310/22, P568411/1

Installation Guide:

1. Installation must be carried out by a competent electrician, skilled in cable gland installation.
2. Installation should not be carried out under live conditions.
3. Once installed do not dismantle except for occasional inspection. If necessary, dismantle by reverting the installation instruction. The gland is not serviceable and spare parts are not supplied separately.
4. Parts of glands are not interchangeable with any other design. If manufacturer's parts are mixed, certification will be invalidated.
5. The female thread in the enclosure must comply with relevant standard and do not damage threads on assemblies.
6. The glands should only be used with substantially round and compact cables with correct tools.
7. Installation should only be performed by a competent person using the correct torque tools. Spanners should be used for tightening. Read all instructions before beginning installation.

8. Any modification which differs from the condition as delivered is not permitted.
9. Accessories are available from CABTEK, as optional extras, to assist with fixing, sealing and earthing, Locknut, Earth Tag, Serrated Washer, Entry Thread seal (IP), Shroud.

Special Condition of Safe Use of Cable Glands:

1. Cable Glands are only suitable for fixed installations.
2. Cable must be effectively clamped from pulling and twisting.
3. Cable Glands shall not be used in enclosure where the temperatures at the point of entry /mounting are outside the range of ambient temperatures as detailed in general description.
4. The glands should only be used with substantially round cables and tightened to the rated torque with torque wrenches.
5. Install in accordance with requirements of EN60079-14.
6. The cable glands are provided with a sealing ring with an axial sealing height of at least 5 mm. With reference to the clearance groove, the end-user should ensure that at least five complete turns of the connector thread are made. In order to guarantee a screw depth of 8 mm, the enclosure should have a wall thickness of min. 10mm; if <10 mm, then if necessary, use a washer when cable entries are attached to the pressure-resistant enclosure.
7. In the case of NPT connecting threads, the end-user must ensure that the necessary IP protection is guaranteed; this can be done using a suitable thread sealing agent.
8. Installation should not be carried out under live conditions.

CABLE GLAND ORDERING DETAILS:

Product Code for Ordering Purpose

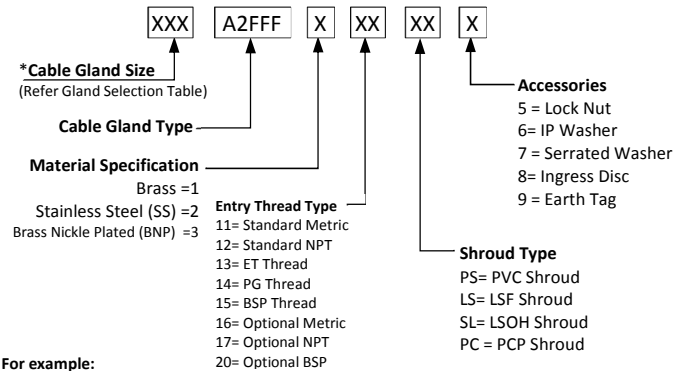

For example:

20A2FFF31PS6 = A2FFF-20-M20 Nickel Plated Cable Gland with PVC Shroud & IP Washer

20A2FFF31PS69 = A2FFF-20-M20 Nickel Plated Cable Gland Kit*

(*Kit includes PVC Shroud(PS), Lock Nut(5), IP Washer(6) & Tag(9)

For cable gland technical details like Cable Gland Size, Cable diameter, thread and torque details given as below.

Cable Gland Selection Table for Fig 5 to 9

*Cable Gland Size	Standard Entry Thread "C"			Entry Thread Length		Entry Thread "C"		Cable Range		No. of Flat Cable used	Entry Component & Seal Nut		Assembly Length		Torque (Nm)	
	Metric	NPT/BSPP	ET	PG	Metric	NPT	Metric	NPT/BSPP	Min		Max	Across Flat A/F	Across Corner A/C	Uncompressed Length "L"		Compressed Length "C"
20s	M20x1.5	1/2"	3/4"	PG13.5	15.00	16.00	M25x1.5	3/4"	4x6.2	6.8x11.7	1	24.00	26.20	32.75	27.30	40
20	M20x1.5	1/2"	3/4"	PG16	15.00	16.00	M25x1.5	3/4"	5.7x8	8.7x13.5	1	27.00	29.50	33.00	27.80	40
20A	M20x1.5	1/2"	3/4"	PG16	15.00	16.00	M25x1.5	3/4"	1.4x4.0	1.75x4.6	3	27.00	29.50	33.00	27.80	40
20B	M20x1.5	1/2"	3/4"	PG16	15.00	16.00	M25x1.5	3/4"	1.4x4.0	1.75x4.6	6	27.00	29.50	33.00	27.80	40
25s	M25x1.5	3/4"	1"	PG21	15.00	19.00	M32x1.5	1"	4x6.2	6.8x11.7	2	36.00	39.20	38.50	36.80	45
25	M25x1.5	3/4"	1"	PG21	15.00	19.00	M32x1.5	1"	5.7x8	8.7x13.5	1	36.00	39.20	38.50	36.80	45
32s	M32x1.5	1"	1.1/4"	PG29	15.00	16.00	M40x1.5	1.1/4"	4x6.2	6.8x11.7	3	41.00	45.00	40.00	37.90	55
32	M32x1.5	1"	1.1/4"	PG29	15.00	16.00	M40x1.5	1.1/4"	5.7x8	8.7x13.5	3	41.00	45.00	40.00	37.90	55

INSTALLATION INSTRUCTIONS FOR CABLE GLAND TYPES A2FFF

1. It is not necessary to separate components of the cable gland any further than illustrated below.

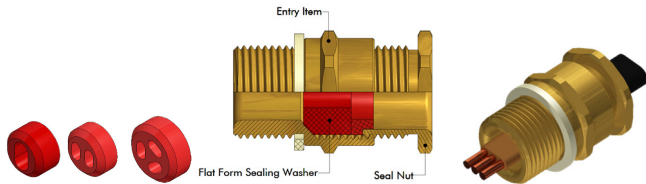

2. Fit the gland into the equipment and fully tighten the entry item. Thread seal will engage when fully tightened.

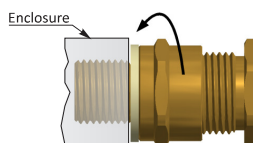

3. Determine the conductor length required to suite the equipment and prepare the cable accordingly. Remove the Outer sheath of cable as per requirement to see the insulated conductors.



4. Check the seal in the entry Item and it is in a relaxed state by loosening the outer seal nut.

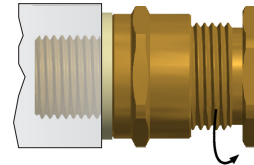

5. Insert Cable through the cable gland. Position Cable correctly. Then tighten the outer seal nut by hand into the entry item until heavy resistance is felt or seal grip the outer sheath of cable. Then tighten the seal nut with torque wrench. For correct torque see Gland selection table.

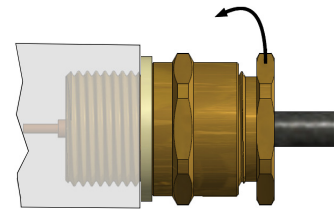

Warning:

Please study carefully these instructions before installation. These glands should not be used in any application other than those mentioned here, unless CABTEK states in writing that the product is suitable for such application. CABTEK will not take any responsibility for any damage, injury or other consequential loss caused where the glands are not installed or used according to installation instructions. This leaflet is not intended to advice on the selection of cable glands. Installation must be carried out by a competent electrician, skilled in cable gland installation. Installation should not be carried out under live conditions.

Customer Care:

For any more information regarding please send your query to us by mail or telephone number

Tel.: + 91-76006 16887, 94277 71205

Email: info@aksharbrassind.com, Website: www.aksharbrassind.com



AKSHAR BRASS INDUSTRIES