

Installation Manual for E1F Cable Gland

E1F Series of Flameproof and Increased Safety Cable Glands suitable for Armoured Cables

Please read all instructions carefully before beginning the installation

CABTEK E1F type Cable Glands are for indoor and Outdoor use in the appropriate Hazardous Areas with Armoured Cable. They seal on the outer jacket and give environmental protection to IP66/67. They are suitable for normal industrial environmental of temperature, humidity and vibration.

Cable Glands are made of Brass CW614N/SS316L & assembled with VMQ Silicone Rubber and Nylon Substrate.

Material Compatibility under chemical corrosion or attack by aggressive substance must be considered before installation.

Cable Gland conform to following Standards for Group II, Category - 2 for Zone 1, 2, 21 & 22 for ambient temperature range -60°CsTas+125°C.

Standards Applied: EN IEC 60079-0: 2018
EN/IEC 60079-1: 2014
EN/IEC 60079-31: 2014/2013



Ex marking on E1F type Cable Gland

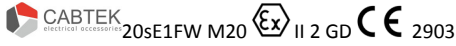

Ex db IIC Gb, Ex eb IIC Gb.....
Ex tb IIIC Db IP66/67.....
-60°CsTas+125°C.....
ETL22ATEX0109X, IECEx ITS 16.0041X.....
RU C-IN.Ж58.B.03310/22, P568411/1.....

Installation Guide:

1. Installation must be carried out by a competent electrician, skilled in cable gland installation.
2. Installation should not be carried out under live conditions.
3. Once installed do not dismantle except for occasional inspection. If necessary, dismantle by reverting the installation instruction. The gland is not serviceable and spare parts are not supplied separately.
4. Parts of glands are not interchangeable with any other design. If manufacturer's parts are mixed, certification will be invalidated.
5. The female thread in the enclosure must comply with relevant standard and do not damage threads on assemblies.
6. The glands should only be used with substantially round and compact cables with correct tools. Installation should only be performed by a competent person using the correct torque tools. Spanners should be used for tightening. Read all instructions before beginning installation.

7. Any modification which differs from the condition as delivered is not permitted.
8. Accessories are available from CABTEK, as optional extras, to assist with fixing, sealing and earthing, Locknut, Earth Tag, Serrated Washer, Entry Thread seal (IP), Shroud.

Special Condition of Safe Use of Cable Glands:

1. Cable Glands are only suitable for fixed installations.
2. Cable must be effectively clamped from pulling and twisting.
3. Cable Glands shall not be used in enclosure where the temperatures at the point of entry /mounting are outside the range of ambient temperatures as detailed in general description.
4. The glands should only be used with substantially round cables and tightened to the rated torque with torque wrenches.
5. Install in accordance with requirements of EN60079-14.
6. The cable glands are provided with a sealing ring with an axial sealing height of at least 5 mm. With reference to the clearance groove, the end-user should ensure that at least five complete turns of the connector thread are made. In order to guarantee a screw depth of 8 mm, the enclosure should have a wall thickness of min. 10mm; if <10 mm, then if necessary, use a washer when cable entries are attached to the pressure-resistant enclosure.
7. In the case of NPT connecting threads, the end-user must ensure that the necessary IP protection is guaranteed; this can be done using a suitable thread sealing agent.
8. Installation should not be carried out under live conditions.

CABLE GLAND ORDERING DETAILS:

Product Code for Ordering Purpose

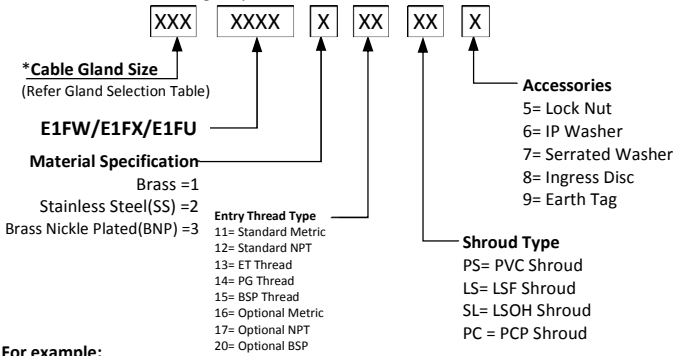

For example:

20sE1FW311PS6 = E1FW-20s-M20 Nickel Plated Cable Gland with PVC Shroud & IP Washer
20sE1FW311PS569 = E1FW-20s-M20 Nickel Plated Cable Gland PS Kit*
(*Kit includes PVC Shroud(PS), Lock Nut(5), IP washer(6) & Earth Tag(9)

For cable gland technical details like Cable Gland Size, Cable diameter, thread and torque details given as below.

Cable Gland Size	Standard Entry			Entry Thread Length			Entry Thread "C"			Armoured Wire Dia		Strip /Braid Size		Cable Diameter		Seal Nut		Assembly Length		Torque (Nm)	
	Metric	NPT/BSPP	ET	PG	Metric	NPT	Optional	Min	Max	Min	Max	Min	Max	AP	AS	Compress	Uncompress	Length "C"			
16	M16x1.5	3/8"	5/8"	PG9	15.0/20.0	15.0/20.0	-	0.90	0.90	0.30	1.00	3.10	8.60	6.10	13.10	24.00	26.20	61.00	69.00	25	
20s16	M20x1.5	1/2"	3/4"	PG11	15.0/20.0	15.0/20.0	M25x1.5	3/4"	0.90	0.90	0.30	1.00	3.10	8.60	6.10	13.10	24.00	26.20	61.00	69.00	25
20s	M20x1.5	1/2"	3/4"	PG13.5	15.0/20.0	15.0/20.0	M25x1.5	3/4"	0.90	1.25	0.30	1.00	6.20	11.70	9.50	15.90	24.00	26.20	60.50	68.50	25
20	M20x1.5	1/2"	3/4"	PG16	15.0/20.0	15.0/20.0	M25x1.5	3/4"	0.90	1.25	0.40	1.00	6.50	13.90	12.50	20.90	30.00	33.00	64.00	72.00	25
25s	M25x1.5	3/4"	1"	PG21	15.0/20.0	15.0/20.0	M32x1.5	1"	1.25	1.60	0.40	1.20	9.50	15.40	14.00	22.00	36.00	39.20	80.00	89.00	30
25	M25x1.5	3/4"	1"	PG24	15.0/20.0	15.0/20.0	M32x1.5	1"	1.25	1.60	0.40	1.20	11.30	19.90	19.90	36.20	56.00	59.20	79.00	88.00	30
32	M32x1.5	1"	1 1/4"	PG29	15.0/20.0	15.0/20.0	M40x1.5	1 1/4"	1.60	2.00	0.40	1.20	17.00	26.20	23.70	33.90	46.00	50.60	81.00	91.00	35
40	M40x1.5	1 1/4"	1 1/2"	PG36	15.0/20.0	15.0/20.0	M50x1.5	1 1/2"	1.60	2.00	0.40	1.60	23.60	32.10	27.90	40.40	55.00	60.00	81.50	91.50	45
50s	M50x1.5	1 1/2"	2"	PG42	15.0/20.0	15.0/20.0	M63x1.5	2"	2.00	2.50	0.40	1.60	31.50	38.20	35.20	46.70	60.00	65.00	82.00	92.00	60
50	M50x1.5	2"	2"	PG48	15.0/20.0	15.0/20.0	M63x1.5	2 1/2"	2.00	2.50	0.60	1.60	35.80	44.00	40.40	53.00	70.00	75.00	85.00	97.00	65
63s	M63x1.5	2"	2 1/2"	PG48	15.0/20.0	15.0/20.0	M75x1.5	2 1/2"	2.00	2.50	0.60	1.60	41.70	50.00	45.60	59.40	75.00	80.00	89.00	101.00	65
63	M63x1.5	2 1/2"	2 1/2"	-	15.0/20.0	15.0/20.0	M75x1.5	3"	2.00	2.50	0.60	1.60	47.50	56.00	54.60	65.80	80.00	85.00	91.00	103.00	75
75s	M75x1.5	2 1/2"	3"	-	15.0/20.0	15.0/20.0	M90x2	3"	2.00	2.50	0.60	1.60	55.00	62.00	59.60	72.00	90.00	95.00	102.00	115.00	80
75	M75x1.5	3"	3"	-	15.0/20.0	15.0/20.0	M90x2	3 1/2"	2.50	3.00	0.60	1.60	62.00	68.00	66.70	78.40	100.00	104.00	117.00	80	
90	M90x2	3 1/2"	3 1/2"	-	18.0/22.0	18.0/22.0	M106x2	4"	3.00	3.50	0.80	1.60	67.00	79.00	76.20	90.30	112.00	122.00	132.00	145.00	110

INSTALLATION INSTRUCTIONS FOR CABLE GLAND TYPES E1F.

It is not necessary to dismantled the cable gland assembly as shown below

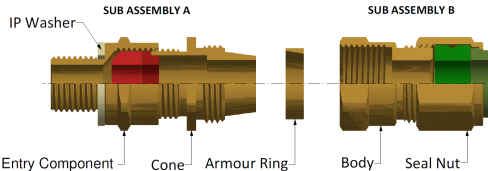

1. Prepare the cable by stripping back the cable outer sheath and armour to suit the equipment geometry. Expose the armour by stripping back the outer sheath further using the table below as a guide. If applicable remove any tapes or wrappings to expose cable inner sheath.

Cable	B	A	Gland Size		Cable Strip "A"	Cable Bedding "B"
			16, 20s16, 20s, 20	25s, 25, 32, 40		
					12mm	35
					15mm	40
					18mm	42
					20mm	50

2. Separate the gland into two sub-assemblies "A & B". Ensuring that the Outer Seal Nut is relaxed, pass sub-assembly "B" over the cable outer sheath and armour followed by the Armour Ring.

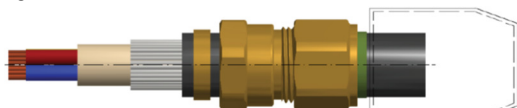

3. Ensure that the inner seal is relaxed by slackening the Main Item. Secure sub-assembly "A" into the equipment either by screwing the Entry Item into a threaded hole or by securing it in a clearance hole using a locknut as applicable.

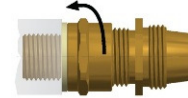

4. Locate the Armour Ring into its recess in the Main Item. Pass the cable through sub-assembly "A" until the armour engaged with the cone. Spread the armour evenly around the cone.

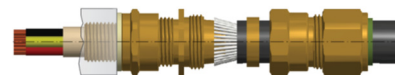

5. While continuing to push the cable forward to maintain contact between the armour and the cone, tighten the Main Item (cone) until the inner seal makes contact with the cable inner sheath (heavier resistance is felt at this point). Tighten a further full turn.

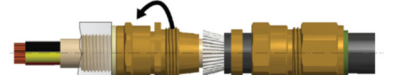

6. Hold the Main Item (2) with a spanner and tighten sub-assembly "B" onto sub-assembly "A" using a spanner until all available threads are used.



7. Only using finger pressure, tighten the outer seal nut assembly (6) until light resist-ance to tightening is met. Then either use the outer seal tightening guide tape or table on the rear of the page to determine how much further to tighten the seal using a spanner (using the outer seal tightening guide is recommended).



Warning:

Please study carefully these instructions before installation. These glands should not be used in any application other than those mentioned here, unless CABTEK states in writing that the product is suitable for such application. CABTEK will not take any responsibility for any damage, injury or other consequential loss caused where the glands are not installed or used according to installation instructions. This leaflet is not intended to advice on the selection of cable glands. Installation must be carried out by a competent electrician, skilled in cable gland installation. Installation should not be carried out under live conditions.

Customer Care:

For any more information regarding please send your query to us by mail or telephone number
Tel.: + 91-76006 16887, 94277 71205
Email: info@aksharbrassind.com, Website: www.aksharbrassind.com



AKSHAR BRASS INDUSTRIES